

Newly Approved  
According to MID



## FLAWSIC600 Ultrasonic Gas Flow Meter

For Custody Transfer and  
Process Applications



# FLAWSIC600

## Gas flow measurement for process and custody applications

### AREAS OF APPLICATION

- Fiscal metering
- Natural gas production, transportation, distribution and storage
- Onshore and offshore applications
- Dry, wet, corrosive and abrasive gases
- Process control
- Power plants, refineries and chemical industry
- Steam and cryogenic
- Process gases like N<sub>2</sub>, O<sub>2</sub>, H<sub>2</sub>, CO<sub>2</sub>, Cl<sub>2</sub> etc.
- Gases like sour gas or biogas with high H<sub>2</sub>S content

#### FLAWSIC600 2-PATH

- 2 path
- 2" ... 48"/  
DN50 ... DN1200
- Uncertainties of  $\pm 1\%$
- Integrated performance monitoring

#### FLAWSIC600 4-PATH

- 4 path
- 3" ... 48"/  
DN80 ... DN1200
- Uncertainty of  $\pm 0.2\%$
- Integrated performance monitoring

#### FLAWSIC600 2plex

- 4 + 1 path
- 3" ... 48"/  
DN80 ... DN1200
- Uncertainty of  $\pm 0.2\%$
- Integrated performance monitoring
- CBM<sup>1)</sup> by monitoring the installation close to the meter (contamination, blockage and pulsation)
- Redundancy

#### FLAWSIC600 Quatro

- 4 + 4 path
- 3" ... 48"/  
DN80 ... DN1200
- Uncertainty of  $\pm 0.2\%$
- Integrated performance monitoring
- 2 independent fiscal meters in one meter body
- As 8 path version suitable for flow test facilities

<sup>1)</sup> CBM ... Condition Based Maintenance

### KEY FEATURES

- Integrated real-time performance monitoring
- New Software MEPAFLOW600 CBM<sup>1)</sup>
- 3 data logs (hourly, daily and weekly historical data)
- 3 logbooks (alarms, warnings and parameter changes)
- Highly efficient titanium transducers
- Nearly insensitive to regulator noise
- Operation even at atmospheric pressure
- Transducers extractable under line pressure
- Bi-directional measurement with no pressure drop
- Compact 3D design with direct path layout
- Rangeability greater than 100 : 1
- No damage from over-ranging

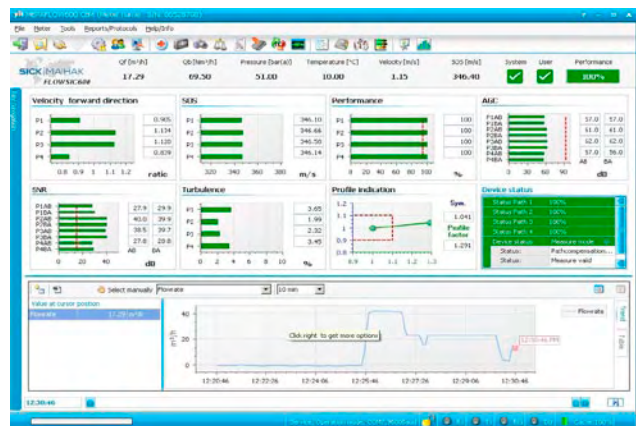

MEPAFLOW600 CBM supports commissioning, diagnosis, meter management and worldwide remote service.



## SYSTEM COMPONENTS

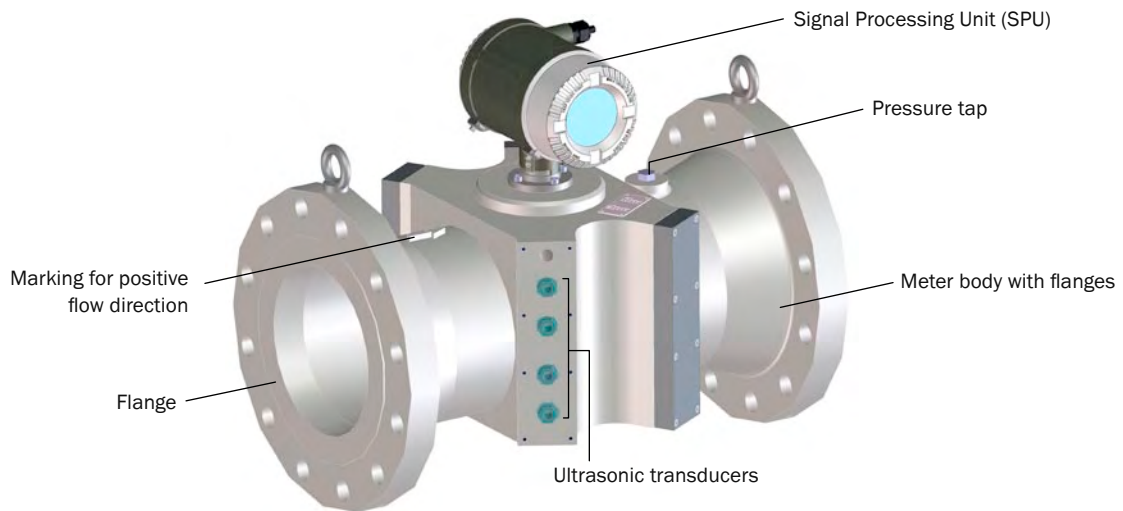

## LEADING EDGE TRANSDUCER TECHNOLOGY

The heart of an ultrasonic flow meter is the ultrasonic transducer. The sealed, titanium transducer design, and the working frequencies of 135 kHz, 210 kHz and 350 kHz, permit using the FLOWSIC600 in virtually all applications in gas flow metering – dry or wet, corrosive or ultrasonically noisy. This characteristics are complemented by a temperature range of  $-194\text{ }^{\circ}\text{C} \dots 280\text{ }^{\circ}\text{C}$  ( $-317\text{ }^{\circ}\text{F} \dots 536\text{ }^{\circ}\text{F}$ ) and a pressure from 450 barg (6500 psig) down to ambient pressure.

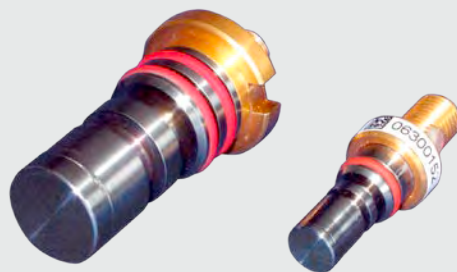

## DIRECT CHORDAL PATH LAYOUT

The direct chordal path layout incorporates distinct advantages. Since the signals are not reflected inside the meter, contamination or changes in wall roughness do not effect the signal strength and signal quality. For this reason long term stability of measurement performance and highest accuracy is achieved. Due to the direct chordal path layout, together with the excellent transducer characteristics, the FLOWSIC600 has an enhanced immunity against control valve noise.

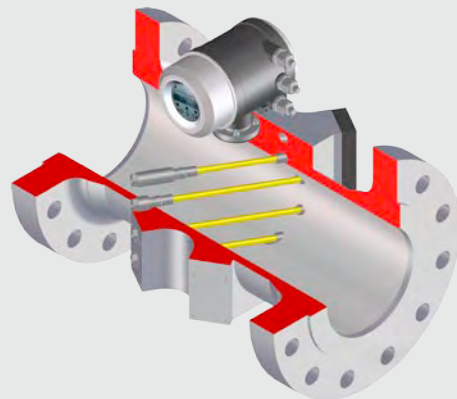

FLOWSIC600		Technical Data							
Meter characteristics									
Nominal size		Flow rate [m <sup>3</sup> /h]		Flow rate [ft <sup>3</sup> /h]		Max. velocity		Length	
		Min.	Max.	Min.	Max.	[m/s]	[ft/s]	[mm]	[in]
DN 50	2"	6	400	210	14,000	65	213	150	5.91
DN 80	3"	12	1,000	280	35,000	65	213	240	9.45
DN 100	4"	20	1,600	460	57,000	60	197	300	11.81
DN 150	6"	32	3,000	1,130	106,000	50	164	450	17.72
DN 200	8"	40	4,500	1,410	159,000	45	148	600	23.62
DN 250	10"	50	7,000	1,770	247,000	40	131	750	29.53
DN 300	12"	65	8,000	2,300	283,000	33	108	900	35.43
DN 350	14"	80	10,000	2,830	353,000	33	108	1,050	41.34
DN 400	16"	120	14,000	4,240	494,000	33	108	1,200	47.24
DN 450	18"	130	17,000	4,590	600,000	33	108	1,350	53.15
DN 500	20"	200	20,000	7,060	706,000	33	108	1,500	59.06
DN 600	24"	320	32,000	11,300	1,130,000	33	108	1,800	70.87
DN 700	28"	650	40,000	22,950	1,413,000	30	98	1,400	55.12
DN 750	30"	650	45,000	22,950	1,589,000	30	98	1,500	59.06
DN 800	32"	800	50,000	28,250	1,766,000	30	98	1,600	62.99
DN 900	36"	1,000	66,000	35,320	2,331,000	30	98	1,800	70.87
DN 1000	40"	1,200	80,000	42,380	2,825,000	30	98	2,000	78.74
DN 1050	42"	1,300	85,000	45,910	3,002,000	30	98	2,100	82.68
DN 1100	44"	1,400	90,000	49,440	3,178,000	28	92	2,200	86.61
DN 1200	48"	1,600	100,000	56,500	3,531,000	27	89	2,400	94.49
Meter body material	<ul style="list-style-type: none"> <li>• Carbon steel 1.1120/ ASME A216 WCC</li> <li>• Stainless steel 1.4408/ ASME A351 Gr. CF 8M</li> <li>• Low temperature carbon steel 1.6220/ASME A352 L CC</li> <li>• Duplex steel 1.4470/ASME A995 Gr.4A/UNS J92205</li> </ul>								
Measuring parameters									
Gases	Natural gas, process gases, air								
Measured value	Volume flow (actual and standard), volume (actual and standard), velocity of gas, speed of sound								
Temperature	-40 °C ... +180 °C (-40 °F ... 365 °F); -194 °C ... +280 °C (-317 °F ... 536 °F) on request								
Pressure range	0 barg ... 250 barg; up to 450 barg on request (0 ... 3600 psig; up to 6500 psig on request)								
Repeatability	< 0.1 %								
Typical uncertainty <sup>1)</sup>	1 path: ± 2.0 %								
	2 paths: ± 1.0 %								
	4 paths: ± 0.5 % (dry calibrated), ± 0.2 % (after flow calibration + adjustment with constant factor) ± 0.1 % (after flow calibration + adjustment with polynomial correction)								
Approvals									
Ex certification	ATEX: II 1/2G EEx de ib [ia] IIA or IIC T4 CSA: Class I, Division 1, Groups D T4; Class I, Division 2, Groups D T4 Class I, Division 1, Groups B,C,D T4; Class I, Division 2, Groups A, B, C, D T4								
Pattern approval	MID, PTB, NMI, Measurement Canada, GOST, ...								
Conformities	OIML R137-1, OIMLD11, A. G. A Report No. 9, API 21.1 (draft), ISO 17089-1 (draft)								
Electrical safety	CE					Enclosure rating: IP 65/IP 67			
Outputs and interfaces									
Analog output	Active/passive; optically isolated; 4 ... 20 mA; max. load = 250 Ω								
Digital outputs	Passive, optically isolated, open collector or according NAMUR, f <sub>max</sub> = 6 kHz								
Interfaces	2 x RS485								
Bus protocol	<ul style="list-style-type: none"> <li>• Modbus ASCII/Modbus RTU</li> <li>• HART protocol</li> </ul>								

<sup>1)</sup> Within Q<sub>1</sub> ... Q<sub>max</sub> with non disturbed inlet/outlet section of 10D/3D